

HOCHIKI CONVENTIONAL DETECTOR RANGE INSTALLATION INSTRUCTIONS

Products Covered: Detectors – SOC-AS3, DCD- A3, DCD-C3, DFJ-A3, DFJ-C3 Bases - YBN-R/6, YBO-R/6PA, YBO-R/6R, YBO-R/6RN

Introduction

The Conventional Detectors listed above all utilise three terminals, which means they can drive a remote indicator. They also operate within a wide voltage range (9.5 - 30V) allowing installation within both fire AND security systems. Each detector can use a common mounting base (YBN-R/6) which is electronics free, or any other base from the range of special bases as shown below:

Detector	Base	Description
SOC-AS3	YBN-R/6	Standard Base
DCD-A3, DCD-C3	YBO-R/6PA	Base for 2wire Systems
DFJ-A3, DFJ-C3	YBO-R/6R	Relay Base (Latching)
	YBO-R/6RN	Relay Base (Non-latching)

Please observe the guidelines below before installation and maintenance. Hochiki cannot guarantee a detector's performance if these guidelines are not followed.

Caution

Hochiki detectors cannot be used to prevent fire itself, they are only intended to detect a certain characteristic of fire. The detector DFJ (Range) and DCD (Range) are used to detect conditions and changes in temperature and cannot detect smoke and other phenomena. When installing the detector, check that the location of each one has been planned according to appropriate fire regulations or recommendations.

Please note: - These Detectors are designed for indoor use only.

Certain actions can cause permanent damage to the detector. If the detector is subjected to any of the following it should not be used (or it should be located where the phenomenon does not exist):

- Situations in which condensation exists.
- Situations in which corrosive gases exists.
- Situations in which obstacles exist, which could impede airflow to the detector.
- Situations in which dust or steam exists
- Disassembly and re-assembly (except SOC -AS3 / SLV-AS3 maintenance).
- Impact or shock.
- Touching the thermistor located in the centre of the detector (DFJ Range and DCD Range Heat detectors only).

If damage is suspected after a fire has occurred, the detector should be replaced. After installation, all detectors on the fire alarm system should be tested to confirm correct operation. Only suitably trained engineers should carry out installations and maintenance. The detector must be subject to periodic maintenance during regular service visits. This period should be outlined in the appropriate standards or recommendations. If there are no such standards existing, Hochiki recommend that the minimum period of maintenance should be 1 year and that the following should be taken into account:

- A regular operation test should be performed.
- A visual check for staining and mechanical damage should be made.
- Operation should only be checked by equipment that is capable of exceeding the required detection threshold. Detector operation should not be tested with a naked flame or open fire.

A dust cover is included with the detector to prevent contamination during installation. **The dust cover must be removed for the detector to operate.**

Head Locking Mechanism

The detectors can be locked onto their relevant bases by removing a plastic lug on the underside of the Detector. The Detector can then be removed by using a special Removal Tool (TSC-A100 / ALG).

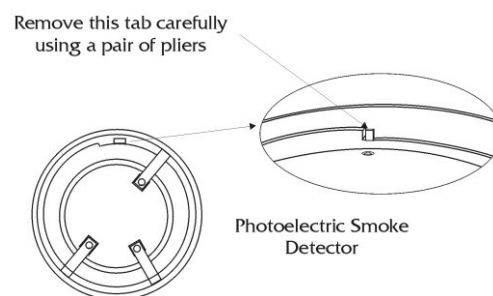

Wiring

The wiring diagram for the conventional detector base should be made as shown.

A: Zone (+) **B:** Zone (-) **C:** Cable Screen

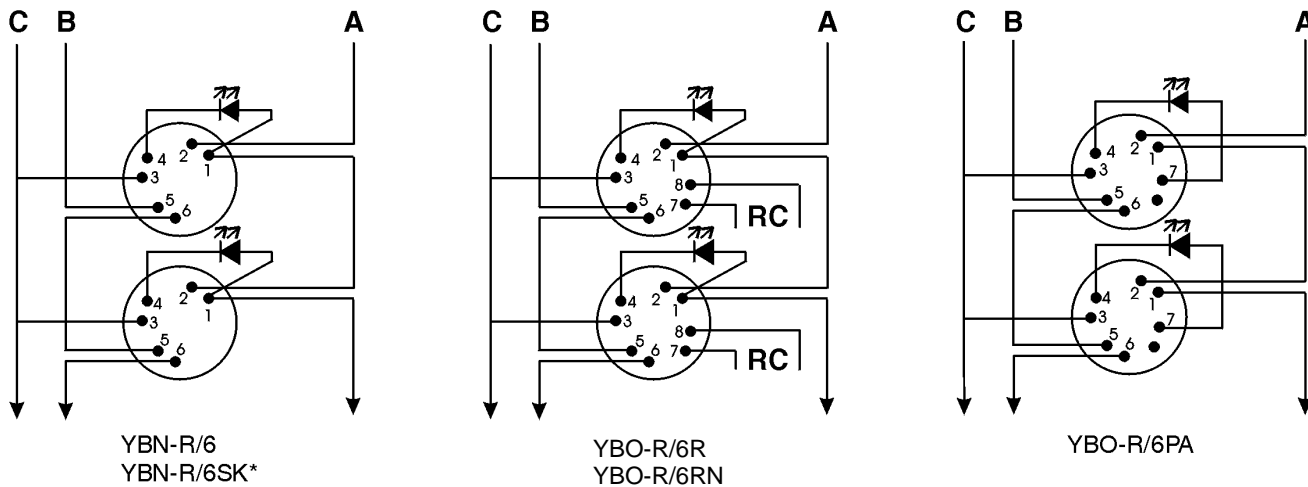

RC Relay Contacts - a flying lead on either terminal 7 or 8 selects either N/C or N/O (supplied as N/C)

Remote Indicator

Note

The YBO-R/6RN base will automatically reset the detector every 8 - 15 seconds after it has entered an alarm state. If the detector remains above its alarm threshold after a reset the LEDs will illuminate again. This will continue until a reset is achieved. The relay contacts (and Remote Indicator) will not change state until the reset is successful.

Detector	Standard
SOC-AS3	AS7240.7
SLV-AS3	AS7240.7
DCD-A3	AS7240.5 Class A1R
DCD-C3	AS7240.5 Class CR
DFJ-A3	AS7240.5 Class A1S
DFJ-C3	AS7240.5 Class CS